



RHEINZINK America, Inc.

REVEAL PANEL DETAILS - VERTICAL

INDEX OF DRAWINGS

- RP-V-1a - HEAD DETAIL - OPTION 1
- RP-V-1b - HEAD DETAIL - OPTION 2
- RP-V-1c - HEAD DETAIL - OPTION 3
- RP-V-2a - JAMB DETAIL - OPTION 1
- RP-V-2b - JAMB DETAIL - OPTION 2
- RP-V-3a - SILL DETAIL - OPTION 1
- RP-V-3b - SILL DETAIL - OPTION 2
- RP-V-3c - SILL DETAIL - OPTION 3
- RP-V-4a - OUTSIDE CORNER DETAIL - OPTION 1
- RP-V-4b - OUTSIDE CORNER DETAIL - OPTION 2
- RP-V-4c - OUTSIDE CORNER DETAIL - OPTION 3
- RP-V-5a - INSIDE CORNER DETAIL - OPTION 1
- RP-V-5b - INSIDE CORNER DETAIL - OPTION 2
- RP-V-6a - BASE TERMINATION - OPTION 1
- RP-V-6b - BASE TERMINATION - OPTION 2
- RP-V-6c - BASE TERMINATION - OPTION 3
- RP-V-7a - PARAPET DETAIL - OPTION 1
- RP-V-7b - PARAPET DETAIL - OPTION 2
- RP-V-7c - PARAPET DETAIL - OPTION 3
- RP-V-8a - CROSS SEAM DETAIL - OPTION 1
- RP-V-8b - CROSS SEAM DETAIL - OPTION 2
- RP-V-8c - CROSS SEAM DETAIL - OPTION 3
- RP-V-8d - CROSS SEAM DETAIL - OPTION 4
- RP-V-9 - PANEL PROFILE

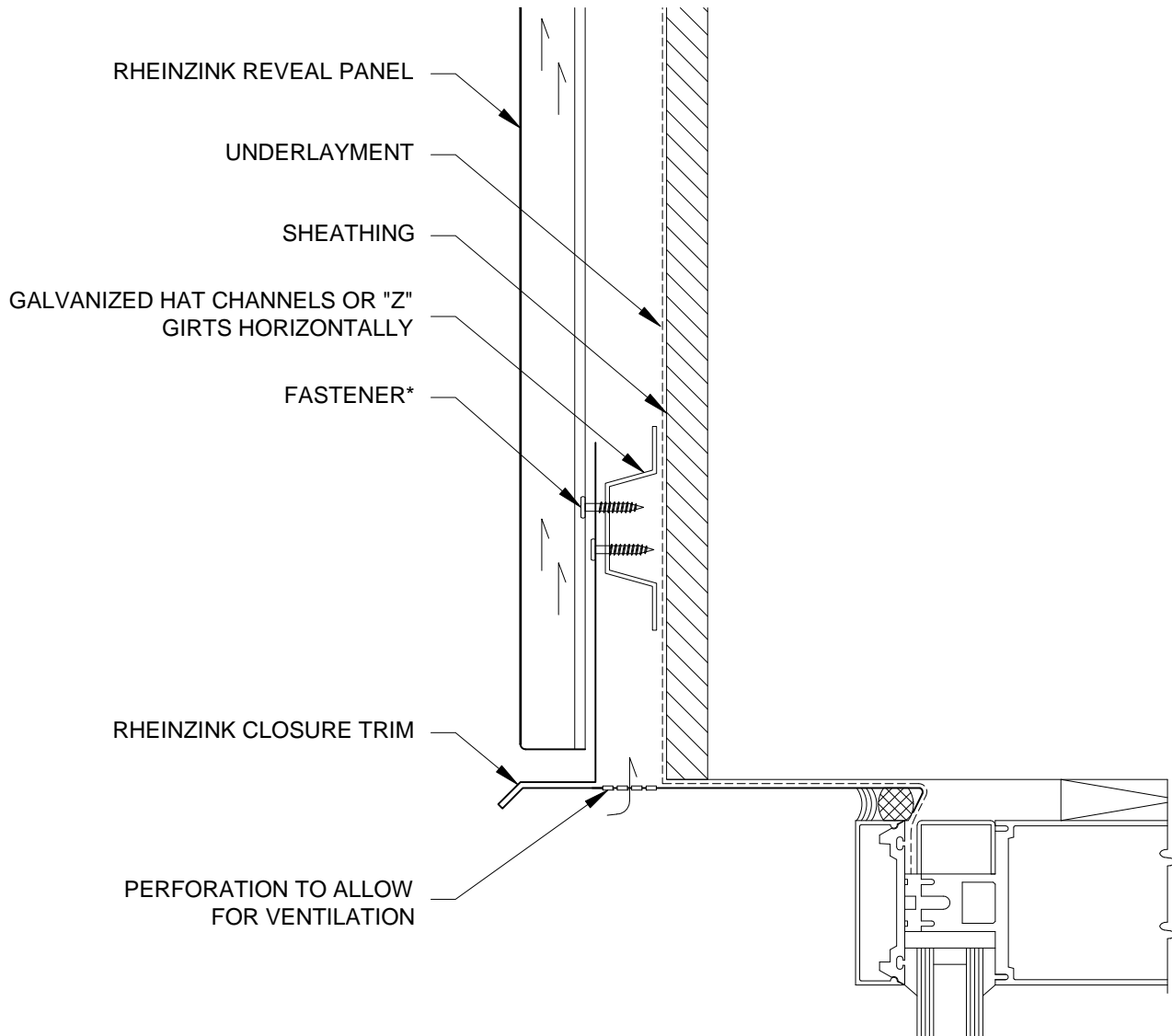

NOTES:

* RHEINZINK RECOMMENDS STAINLESS STEEL FASTENERS AND CLIPS.



Website: www.rheinzink.us E-mail: info@rheinzink.com

INFORMATION AND DETAILS HEREIN ARE ONLY A BASELINE FOR SYSTEM DESIGN AND INSTALLATION. MODIFICATION TO MEET PROJECT REQUIREMENTS IS THE RESPONSIBILITY OF THE DESIGNER AND ARCHITECT. RHEINZINK AMERICA STAFF ARE AVAILABLE TO ASSIST THE DESIGNER AND ARCHITECT IN THIS PROCESS. RHEINZINK AMERICA MAKES NO REPRESENTATIONS AND WARRANTIES OTHER THAN THOSE EXPRESSED HEREIN.

PROJECT:	REVEAL PANEL DETAILS - V	DATE:	08-2011
DRAWING TITLE:	HEAD DETAIL - OPTION 1	SCALE:	N.T.S.
COPYRIGHT RESERVED. THIS DRAWING REMAINS THE PROPERTY OF RHEINZINK.		SHEET:	RP-V-1a

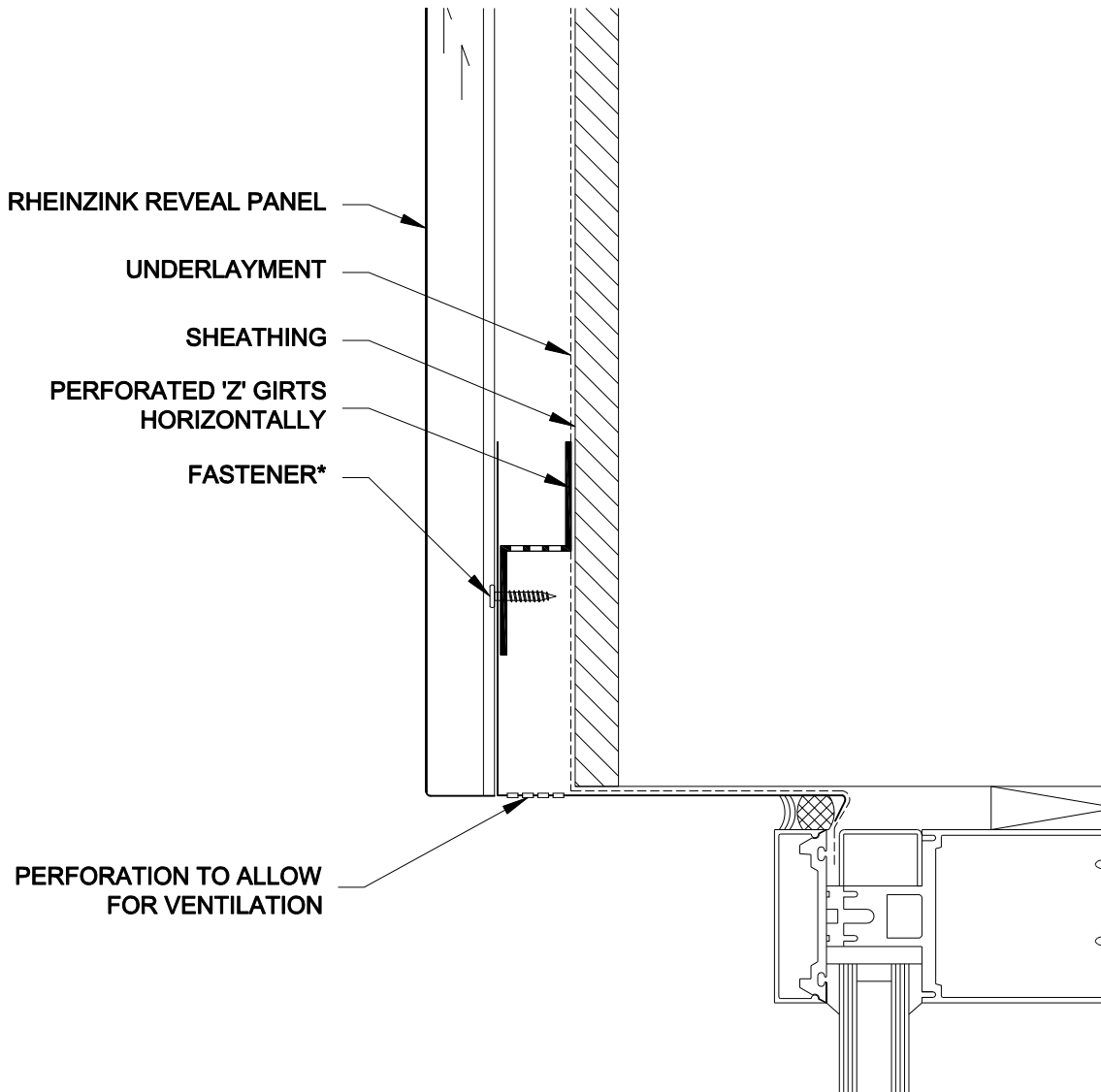

NOTES:

* RHEINZINK RECOMMENDS STAINLESS STEEL FASTENERS AND CLIPS.



Website: www.rheinzink.us E-mail: info@rheinzink.com

INFORMATION AND DETAILS HEREIN ARE ONLY A BASELINE FOR SYSTEM DESIGN AND INSTALLATION. MODIFICATION TO MEET PROJECT REQUIREMENTS IS THE RESPONSIBILITY OF THE DESIGNER AND ARCHITECT. RHEINZINK AMERICA STAFF ARE AVAILABLE TO ASSIST THE DESIGNER AND ARCHITECT IN THIS PROCESS. RHEINZINK AMERICA MAKES NO REPRESENTATIONS AND WARRANTIES OTHER THAN THOSE EXPRESSED HEREIN.

PROJECT:	REVEAL PANEL DETAILS - V	DATE:	08-2011
DRAWING TITLE:	HEAD DETAIL - OPTION 2	SCALE:	N.T.S.
COPYRIGHT RESERVED. THIS DRAWING REMAINS THE PROPERTY OF RHEINZINK.		SHEET:	RP-V-1b

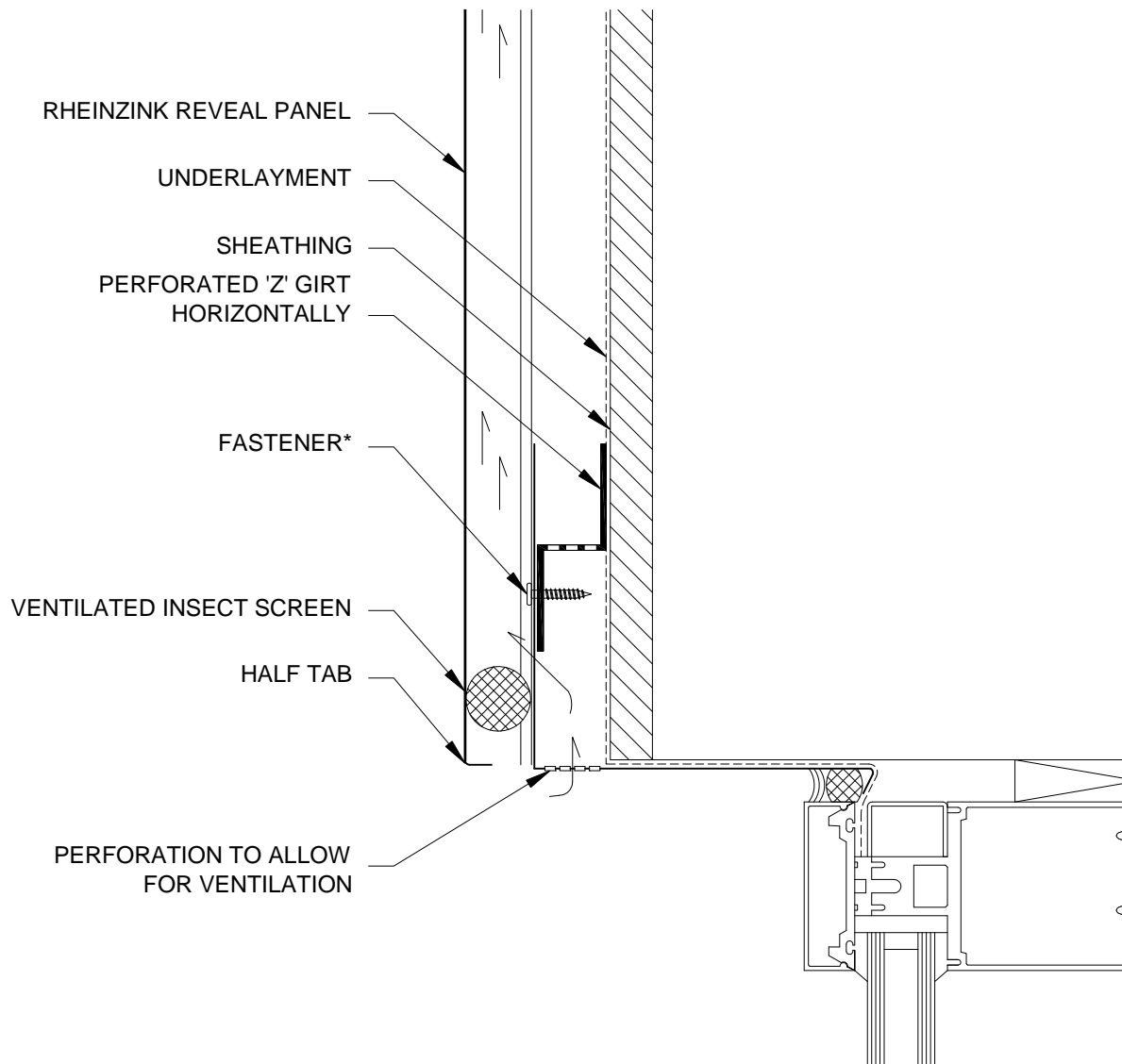

NOTES:

* RHEINZINK RECOMMENDS STAINLESS STEEL FASTENERS AND CLIPS.



Website: www.rheinzink.us E-mail: info@rheinzink.com

INFORMATION AND DETAILS HEREIN ARE ONLY A BASELINE FOR SYSTEM DESIGN AND INSTALLATION. MODIFICATION TO MEET PROJECT REQUIREMENTS IS THE RESPONSIBILITY OF THE DESIGNER AND ARCHITECT. RHEINZINK AMERICA STAFF ARE AVAILABLE TO ASSIST THE DESIGNER AND ARCHITECT IN THIS PROCESS. RHEINZINK AMERICA MAKES NO REPRESENTATIONS AND WARRANTIES OTHER THAN THOSE EXPRESSED HEREIN.

PROJECT:	REVEAL PANEL DETAILS - V	DATE:	08-2011
DRAWING TITLE:	HEAD DETAIL - OPTION 3	SCALE:	N.T.S.
COPYRIGHT RESERVED. THIS DRAWING REMAINS THE PROPERTY OF RHEINZINK.		SHEET:	RP-V-1c

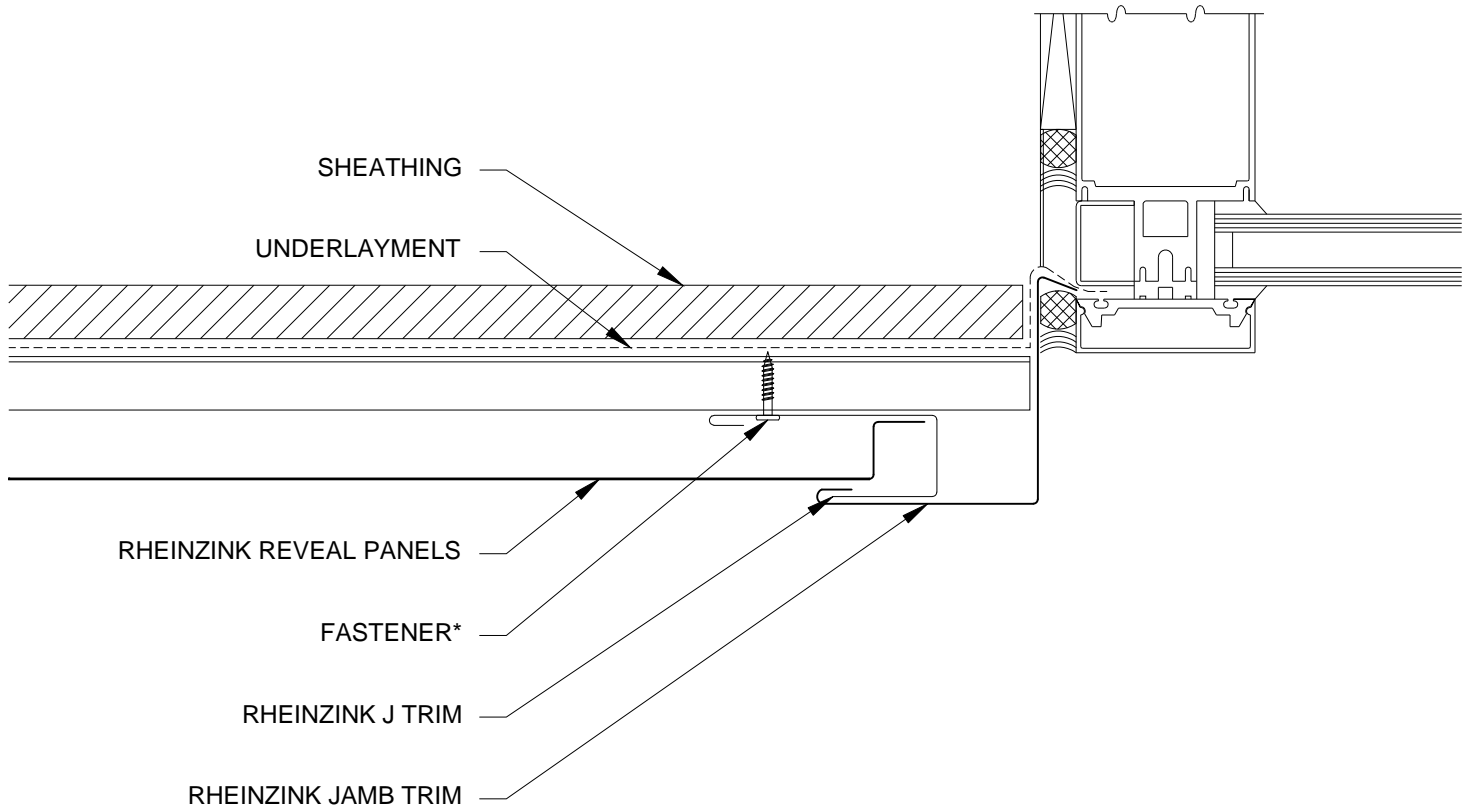

NOTES:

* RHEINZINK RECOMMENDS STAINLESS STEEL FASTENERS AND CLIPS.



Website: www.rheinzink.us E-mail: info@rheinzink.com

INFORMATION AND DETAILS HEREIN ARE ONLY A BASELINE FOR SYSTEM DESIGN AND INSTALLATION. MODIFICATION TO MEET PROJECT REQUIREMENTS IS THE RESPONSIBILITY OF THE DESIGNER AND ARCHITECT. RHEINZINK AMERICA STAFF ARE AVAILABLE TO ASSIST THE DESIGNER AND ARCHITECT IN THIS PROCESS. RHEINZINK AMERICA MAKES NO REPRESENTATIONS AND WARRANTIES OTHER THAN THOSE EXPRESSED HEREIN.

PROJECT:	REVEAL PANEL DETAILS - V	DATE:	02-2012
DRAWING TITLE:	JAMB DETAIL - OPTION 1	SCALE:	N.T.S.
COPYRIGHT RESERVED. THIS DRAWING REMAINS THE PROPERTY OF RHEINZINK.		SHEET:	RP-V-2a

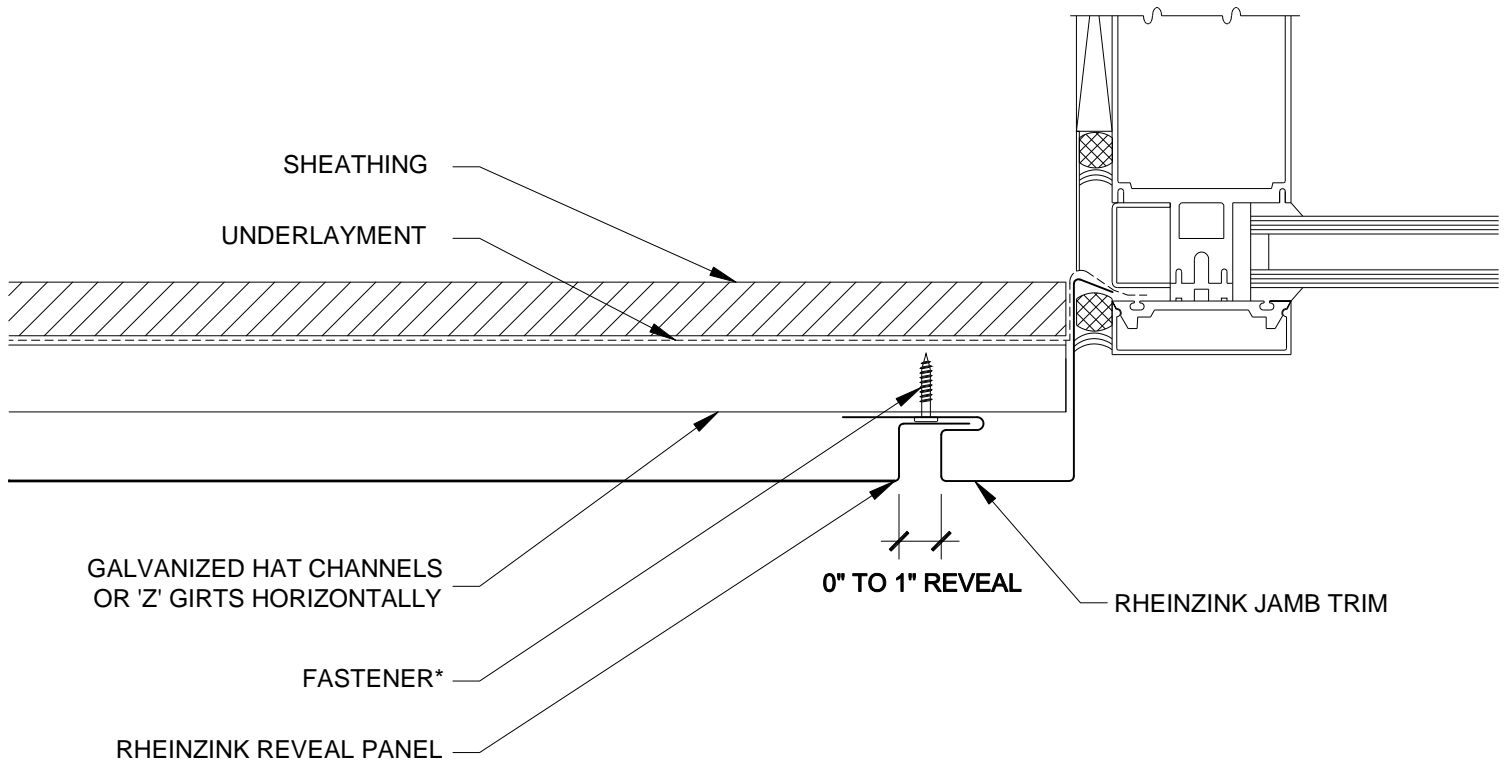

NOTES:

* RHEINZINK RECOMMENDS STAINLESS STEEL FASTENERS AND CLIPS.



Website: www.rheinzink.us E-mail: info@rheinzink.com

INFORMATION AND DETAILS HEREIN ARE ONLY A BASELINE FOR SYSTEM DESIGN AND INSTALLATION. MODIFICATION TO MEET PROJECT REQUIREMENTS IS THE RESPONSIBILITY OF THE DESIGNER AND ARCHITECT. RHEINZINK AMERICA STAFF ARE AVAILABLE TO ASSIST THE DESIGNER AND ARCHITECT IN THIS PROCESS. RHEINZINK AMERICA MAKES NO REPRESENTATIONS AND WARRANTIES OTHER THAN THOSE EXPRESSED HEREIN.

PROJECT:	REVEAL PANEL DETAILS - V	DATE:	08-2011
DRAWING TITLE:	JAMB DETAIL - OPTION 2	SCALE:	N.T.S.
COPYRIGHT RESERVED. THIS DRAWING REMAINS THE PROPERTY OF RHEINZINK.		SHEET:	RP-V-2b

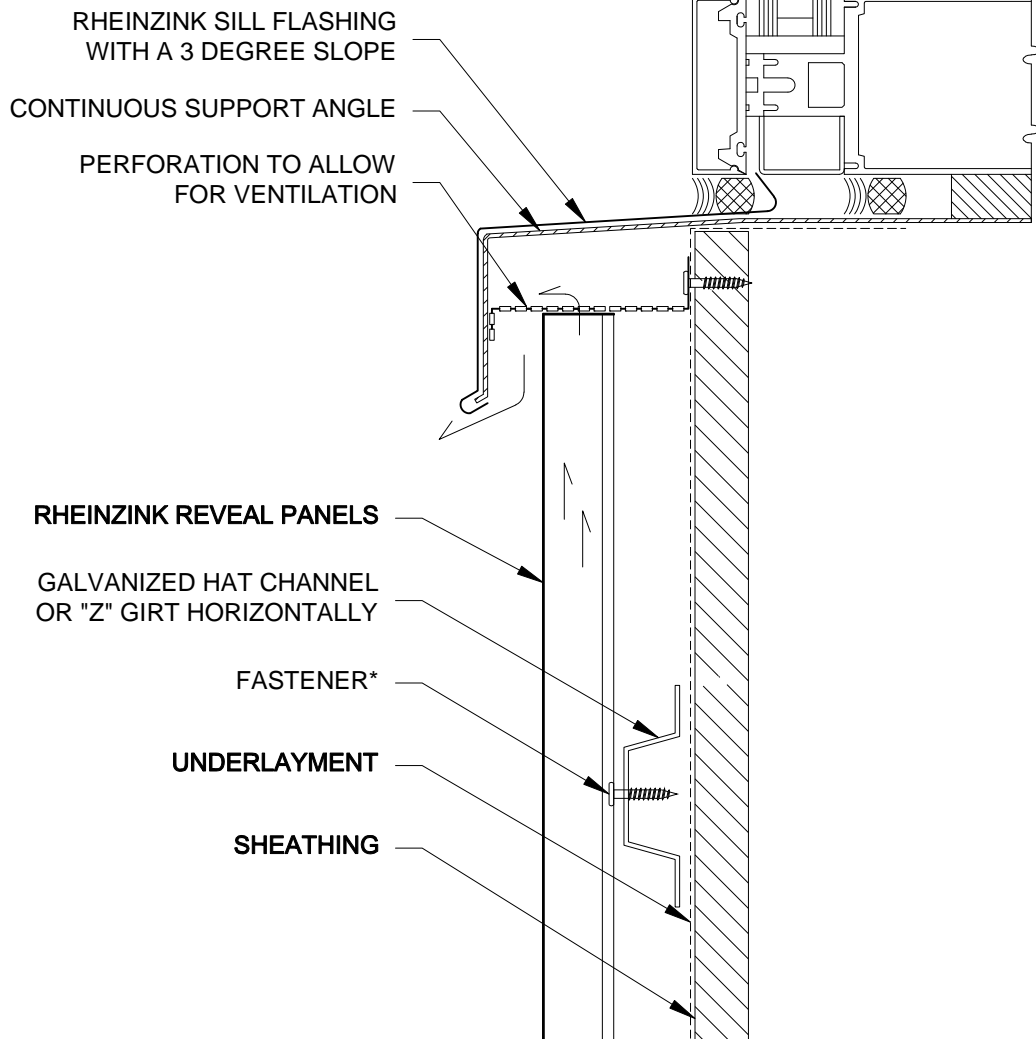

NOTES:

* RHEINZINK RECOMMENDS STAINLESS STEEL FASTENERS AND CLIPS.



Website: www.rheinzink.us E-mail: info@rheinzink.com

INFORMATION AND DETAILS HEREIN ARE ONLY A BASELINE FOR SYSTEM DESIGN AND INSTALLATION. MODIFICATION TO MEET PROJECT REQUIREMENTS IS THE RESPONSIBILITY OF THE DESIGNER AND ARCHITECT. RHEINZINK AMERICA STAFF ARE AVAILABLE TO ASSIST THE DESIGNER AND ARCHITECT IN THIS PROCESS. RHEINZINK AMERICA MAKES NO REPRESENTATIONS AND WARRANTIES OTHER THAN THOSE EXPRESSED HEREIN.

PROJECT:	REVEAL PANEL DETAILS - V	DATE:	08-2011
DRAWING TITLE:	SILL DETAIL - OPTION 1	SCALE:	N.T.S.
COPYRIGHT RESERVED. THIS DRAWING REMAINS THE PROPERTY OF RHEINZINK.		SHEET:	RP-V-3a

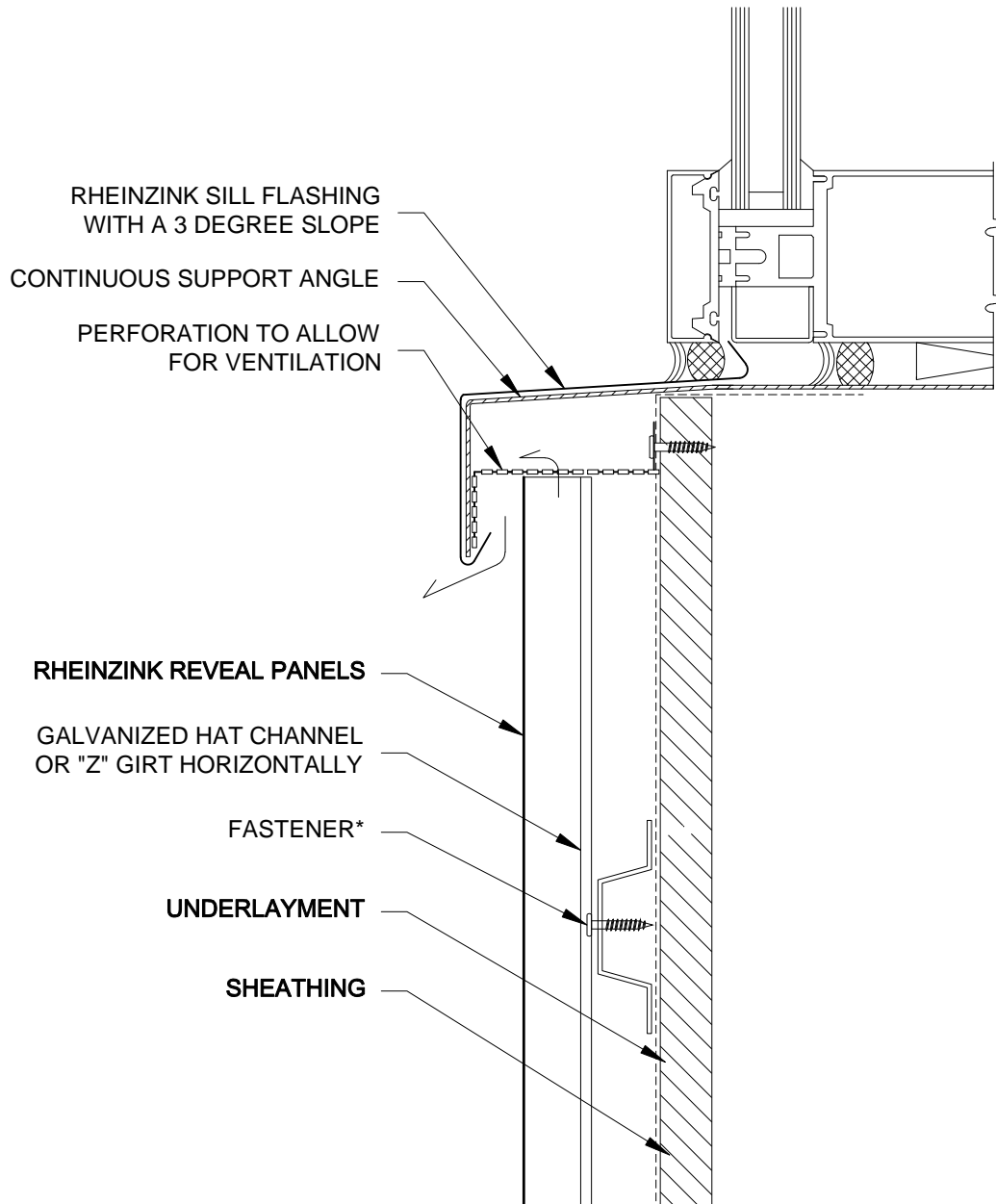

NOTES:

- * RHEINZINK RECOMMENDS STAINLESS STEEL FASTENERS AND CLIPS.



Website: www.rheinzink.us E-mail: info@rheinzink.com

INFORMATION AND DETAILS HEREIN ARE ONLY A BASELINE FOR SYSTEM DESIGN AND INSTALLATION. MODIFICATION TO MEET PROJECT REQUIREMENTS IS THE RESPONSIBILITY OF THE DESIGNER AND ARCHITECT. RHEINZINK AMERICA STAFF ARE AVAILABLE TO ASSIST THE DESIGNER AND ARCHITECT IN THIS PROCESS. RHEINZINK AMERICA MAKES NO REPRESENTATIONS AND WARRANTIES OTHER THAN THOSE EXPRESSED HEREIN.

PROJECT:	REVEAL PANEL DETAILS - V	DATE:	11-2011
DRAWING TITLE:	SILL DETAIL - OPTION 2	SCALE:	N.T.S.
COPYRIGHT RESERVED. THIS DRAWING REMAINS THE PROPERTY OF RHEINZINK.		SHEET:	RP-V-3b

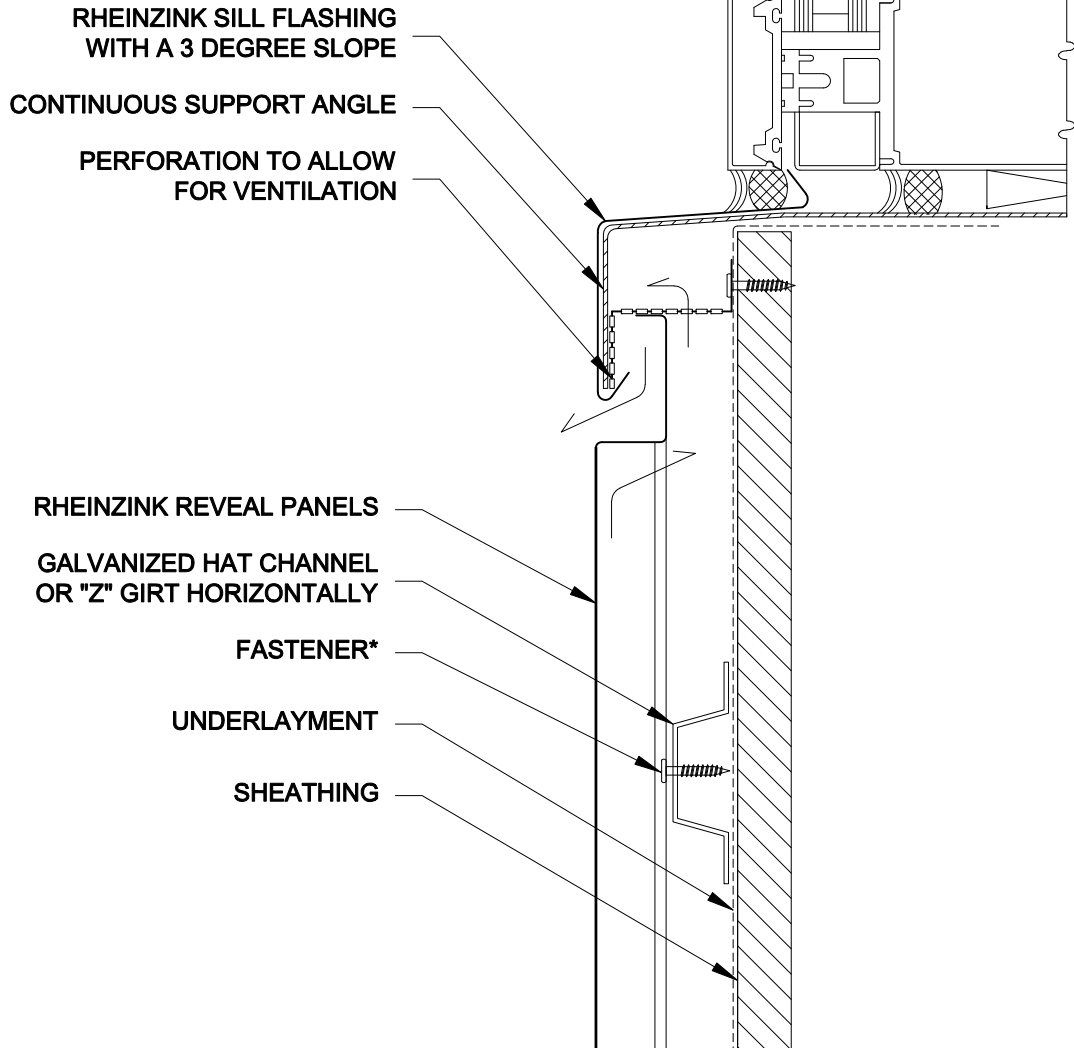

NOTES:

* RHEINZINK RECOMMENDS STAINLESS STEEL FASTENERS AND CLIPS.



Website: www.rheinzink.us E-mail: info@rheinzink.com

INFORMATION AND DETAILS HEREIN ARE ONLY A BASELINE FOR SYSTEM DESIGN AND INSTALLATION. MODIFICATION TO MEET PROJECT REQUIREMENTS IS THE RESPONSIBILITY OF THE DESIGNER AND ARCHITECT. RHEINZINK AMERICA STAFF ARE AVAILABLE TO ASSIST THE DESIGNER AND ARCHITECT IN THIS PROCESS. RHEINZINK AMERICA MAKES NO REPRESENTATIONS AND WARRANTIES OTHER THAN THOSE EXPRESSED HEREIN.

PROJECT:	REVEAL PANEL DETAILS - V	DATE:	08-2011
DRAWING TITLE:	SILL DETAIL - OPTION 3	SCALE:	N.T.S.
COPYRIGHT RESERVED. THIS DRAWING REMAINS THE PROPERTY OF RHEINZINK.		SHEET:	RP-V-3c

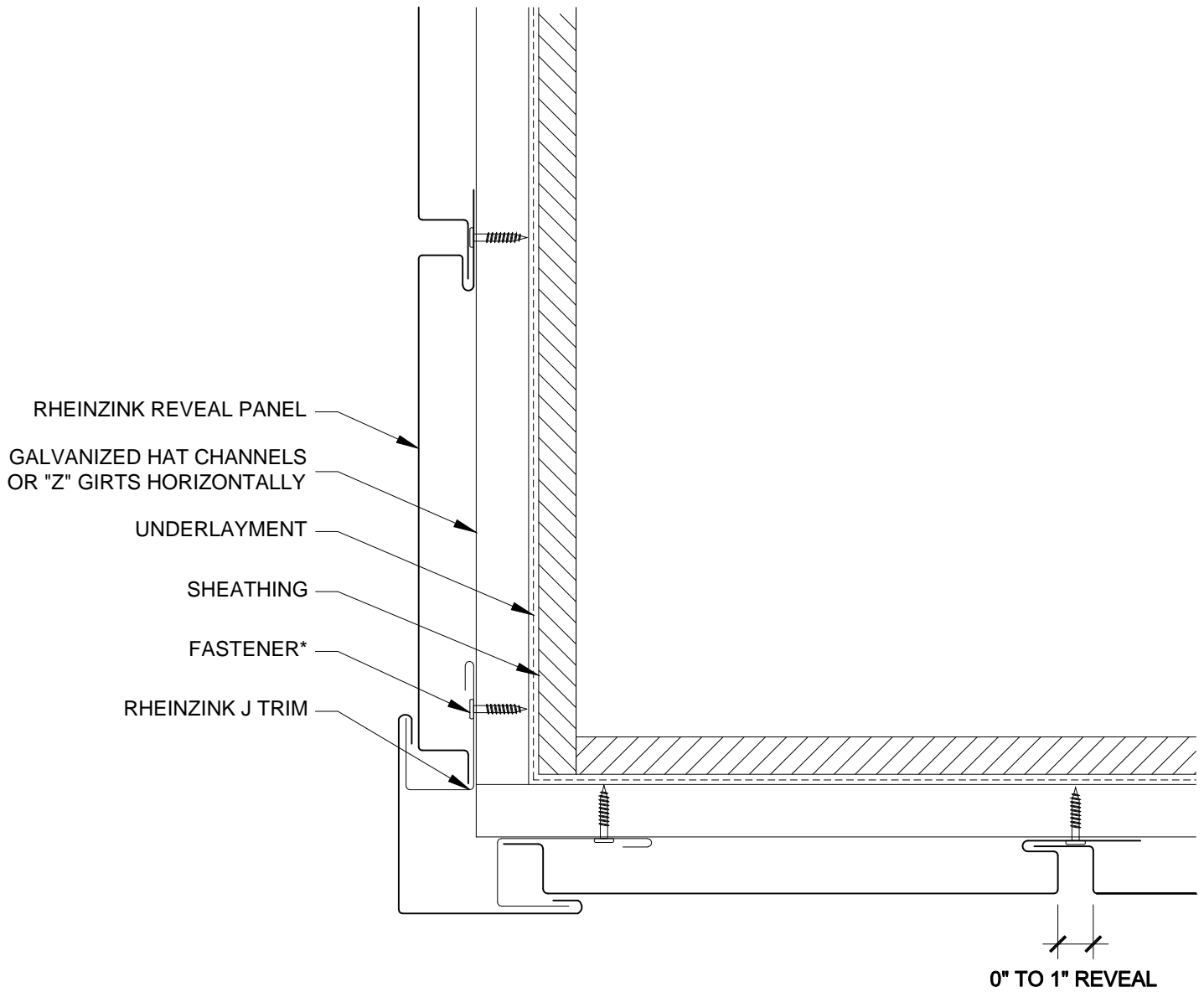

NOTES:

- * RHEINZINK RECOMMENDS STAINLESS STEEL FASTENERS AND CLIPS.



Website: www.rheinzink.us E-mail: info@rheinzink.com

INFORMATION AND DETAILS HEREIN ARE ONLY A BASELINE FOR SYSTEM DESIGN AND INSTALLATION. MODIFICATION TO MEET PROJECT REQUIREMENTS IS THE RESPONSIBILITY OF THE DESIGNER AND ARCHITECT. RHEINZINK AMERICA STAFF ARE AVAILABLE TO ASSIST THE DESIGNER AND ARCHITECT IN THIS PROCESS. RHEINZINK AMERICA MAKES NO REPRESENTATIONS AND WARRANTIES OTHER THAN THOSE EXPRESSED HEREIN.

PROJECT:	REVEAL PANEL DETAILS - V	DATE:	02-2012
DRAWING TITLE:	OUTSIDE CORNER - OPTION 1	SCALE:	N.T.S.
COPYRIGHT RESERVED. THIS DRAWING REMAINS THE PROPERTY OF RHEINZINK.		SHEET:	RP-V-4a

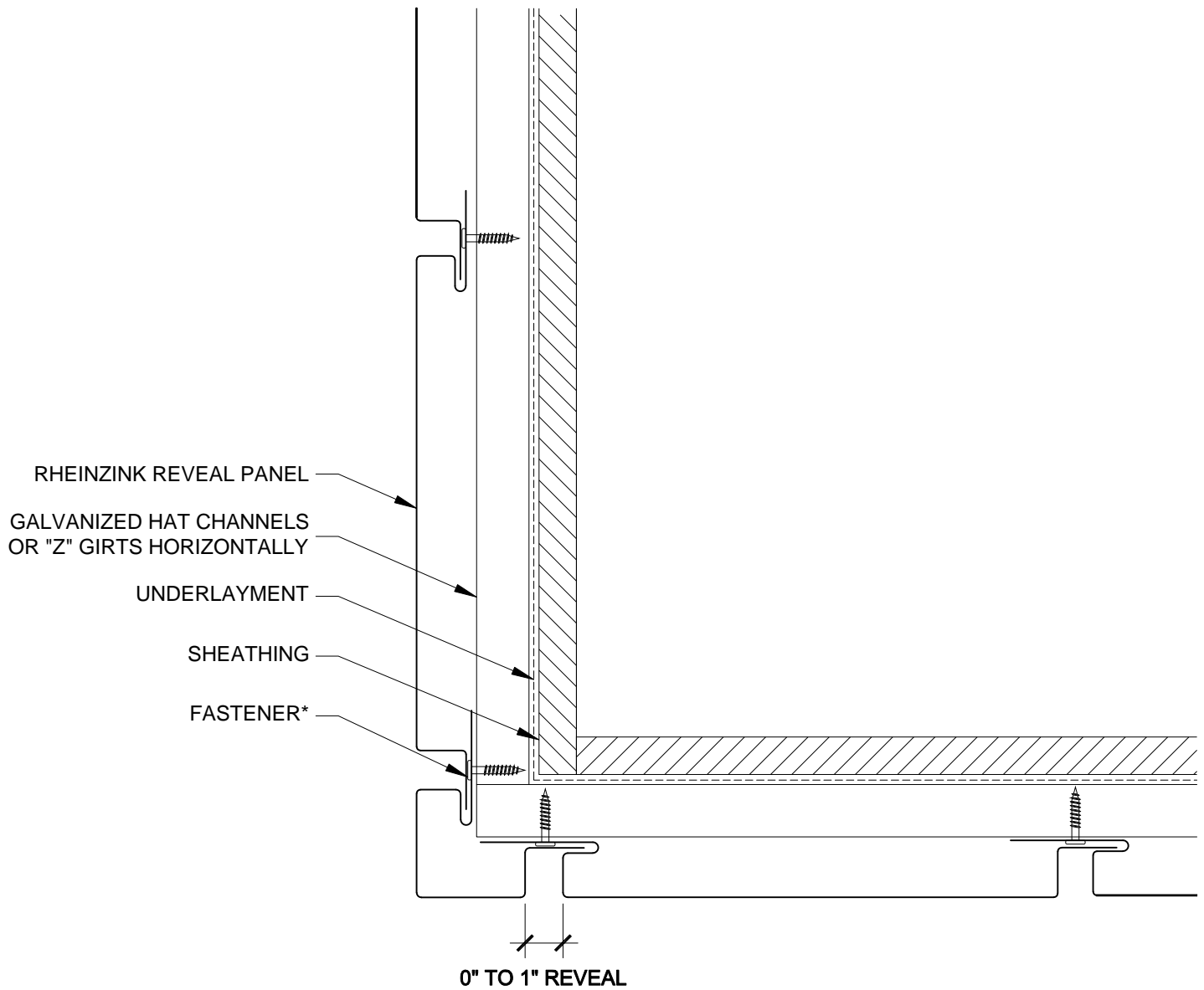

NOTES:

- * RHEINZINK RECOMMENDS STAINLESS STEEL FASTENERS AND CLIPS.



Website: www.rheinzink.us E-mail: info@rheinzink.com

INFORMATION AND DETAILS HEREIN ARE ONLY A BASELINE FOR SYSTEM DESIGN AND INSTALLATION. MODIFICATION TO MEET PROJECT REQUIREMENTS IS THE RESPONSIBILITY OF THE DESIGNER AND ARCHITECT. RHEINZINK AMERICA STAFF ARE AVAILABLE TO ASSIST THE DESIGNER AND ARCHITECT IN THIS PROCESS. RHEINZINK AMERICA MAKES NO REPRESENTATIONS AND WARRANTIES OTHER THAN THOSE EXPRESSED HEREIN.

PROJECT:	REVEAL PANEL DETAILS - V	DATE:	08-2011
DRAWING TITLE:	OUTSIDE CORNER - OPTION 2	SCALE:	N.T.S.
COPYRIGHT RESERVED. THIS DRAWING REMAINS THE PROPERTY OF RHEINZINK.		SHEET:	RP-V-4b

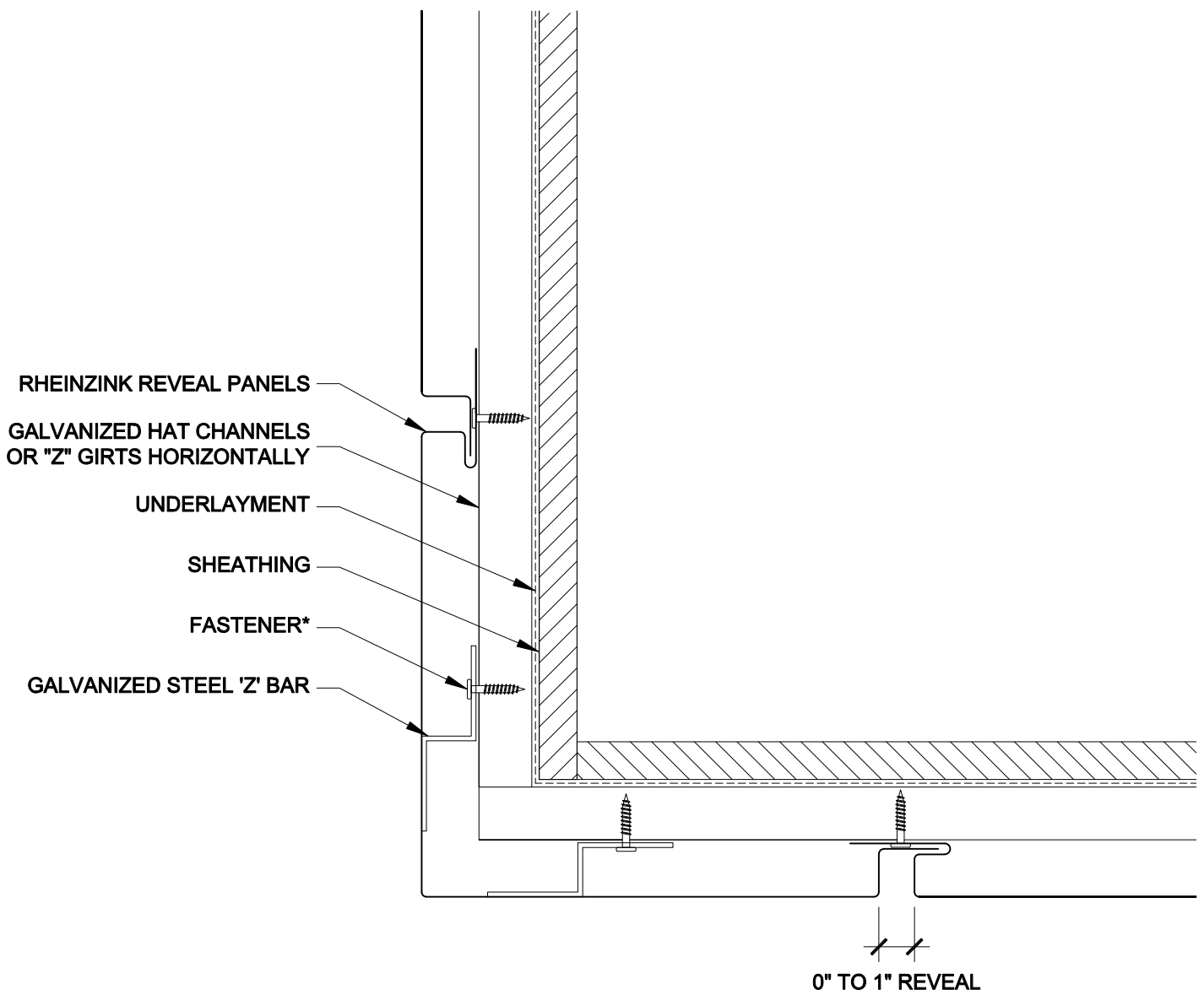

NOTES:

* RHEINZINK RECOMMENDS STAINLESS STEEL FASTENERS AND CLIPS.



Website: www.rheinzink.us E-mail: info@rheinzink.com

INFORMATION AND DETAILS HEREIN ARE ONLY A BASELINE FOR SYSTEM DESIGN AND INSTALLATION. MODIFICATION TO MEET PROJECT REQUIREMENTS IS THE RESPONSIBILITY OF THE DESIGNER AND ARCHITECT. RHEINZINK AMERICA STAFF ARE AVAILABLE TO ASSIST THE DESIGNER AND ARCHITECT IN THIS PROCESS. RHEINZINK AMERICA MAKES NO REPRESENTATIONS AND WARRANTIES OTHER THAN THOSE EXPRESSED HEREIN.

PROJECT:	REVEAL PANEL DETAILS - V	DATE:	08-2011
DRAWING TITLE:	OUTSIDE CORNER - OPTION 3	SCALE:	N.T.S.
COPYRIGHT RESERVED. THIS DRAWING REMAINS THE PROPERTY OF RHEINZINK.		SHEET:	RP-V-4c

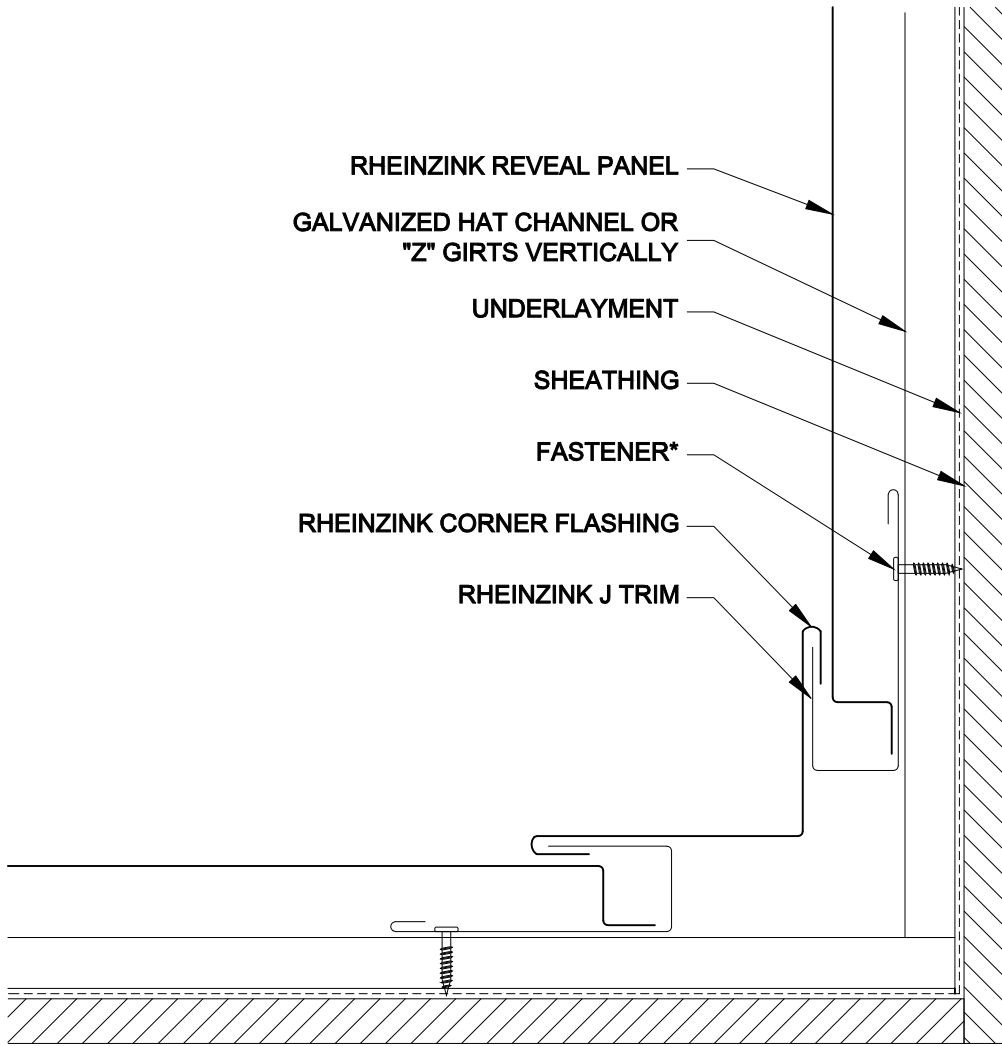

NOTES:

* RHEINZINK RECOMMENDS STAINLESS STEEL FASTENERS AND CLIPS.



Website: www.rheinzink.us E-mail: info@rheinzink.com

INFORMATION AND DETAILS HEREIN ARE ONLY A BASELINE FOR SYSTEM DESIGN AND INSTALLATION. MODIFICATION TO MEET PROJECT REQUIREMENTS IS THE RESPONSIBILITY OF THE DESIGNER AND ARCHITECT. RHEINZINK AMERICA STAFF ARE AVAILABLE TO ASSIST THE DESIGNER AND ARCHITECT IN THIS PROCESS. RHEINZINK AMERICA MAKES NO REPRESENTATIONS AND WARRANTIES OTHER THAN THOSE EXPRESSED HEREIN.

PROJECT:	REVEAL PANEL DETAILS - V	DATE:	11-2011
DRAWING TITLE:	INSIDE CORNER - OPTION 1	SCALE:	N.T.S.
COPYRIGHT RESERVED. THIS DRAWING REMAINS THE PROPERTY OF RHEINZINK.		SHEET:	RP-V-5a

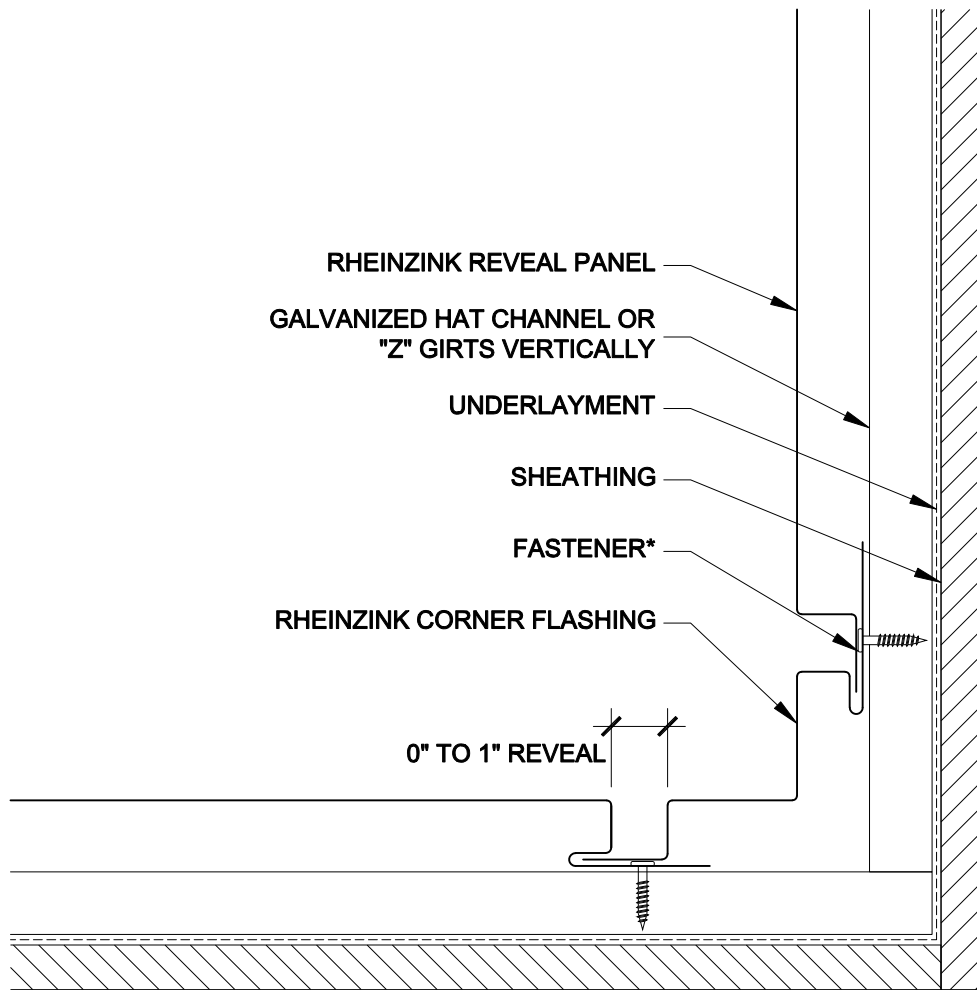

NOTES:

* RHEINZINK RECOMMENDS STAINLESS STEEL FASTENERS AND CLIPS.



Website: www.rheinzink.us E-mail: info@rheinzink.com

INFORMATION AND DETAILS HEREIN ARE ONLY A BASELINE FOR SYSTEM DESIGN AND INSTALLATION. MODIFICATION TO MEET PROJECT REQUIREMENTS IS THE RESPONSIBILITY OF THE DESIGNER AND ARCHITECT. RHEINZINK AMERICA STAFF ARE AVAILABLE TO ASSIST THE DESIGNER AND ARCHITECT IN THIS PROCESS. RHEINZINK AMERICA MAKES NO REPRESENTATIONS AND WARRANTIES OTHER THAN THOSE EXPRESSED HEREIN.

PROJECT:	REVEAL PANEL DETAILS - V	DATE:	08-2011
DRAWING TITLE:	INSIDE CORNER - OPTION 2	SCALE:	N.T.S.
COPYRIGHT RESERVED. THIS DRAWING REMAINS THE PROPERTY OF RHEINZINK.		SHEET:	RP-V-5b

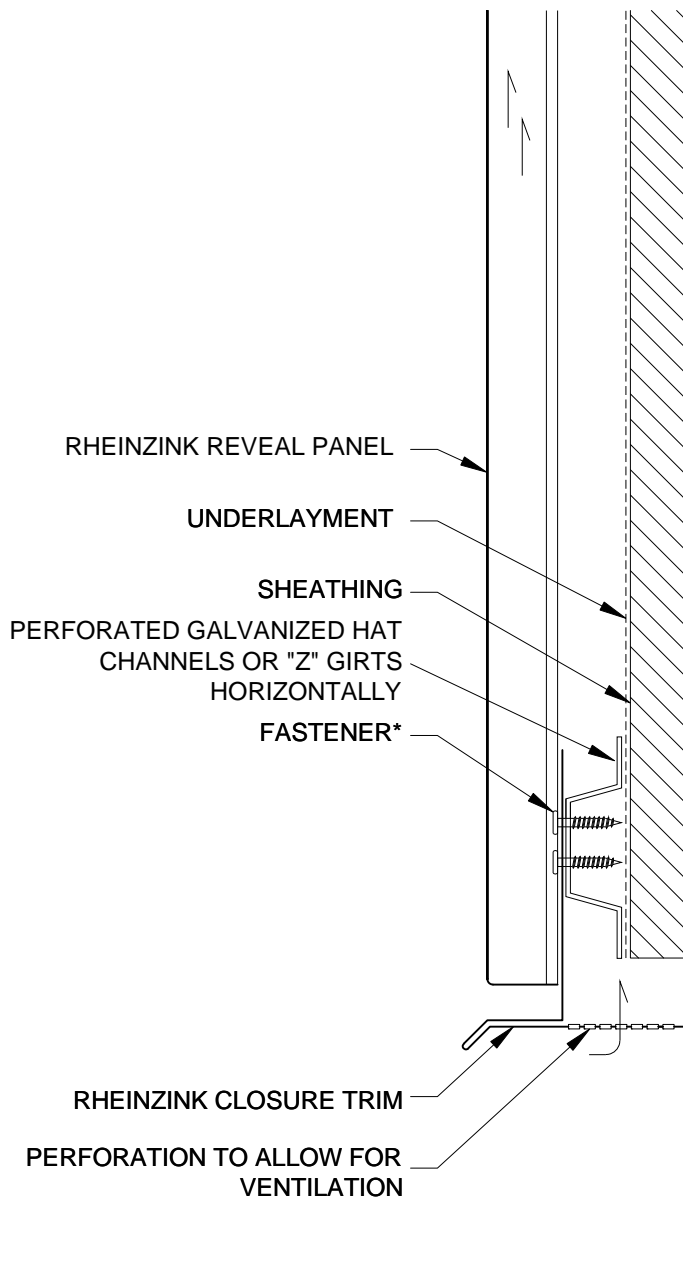

NOTES:

- * RHEINZINK RECOMMENDS STAINLESS STEEL FASTENERS AND CLIPS.



Website: www.rheinzink.us E-mail: info@rheinzink.com

INFORMATION AND DETAILS HEREIN ARE ONLY A BASELINE FOR SYSTEM DESIGN AND INSTALLATION. MODIFICATION TO MEET PROJECT REQUIREMENTS IS THE RESPONSIBILITY OF THE DESIGNER AND ARCHITECT. RHEINZINK AMERICA STAFF ARE AVAILABLE TO ASSIST THE DESIGNER AND ARCHITECT IN THIS PROCESS. RHEINZINK AMERICA MAKES NO REPRESENTATIONS AND WARRANTIES OTHER THAN THOSE EXPRESSED HEREIN.

PROJECT:	REVEAL PANEL DETAILS - V	DATE:	10-2011
DRAWING TITLE:	BASE TERM. DETAIL - OPTION 1	SCALE:	N.T.S.
COPYRIGHT RESERVED. THIS DRAWING REMAINS THE PROPERTY OF RHEINZINK.		SHEET:	RP-V-6a

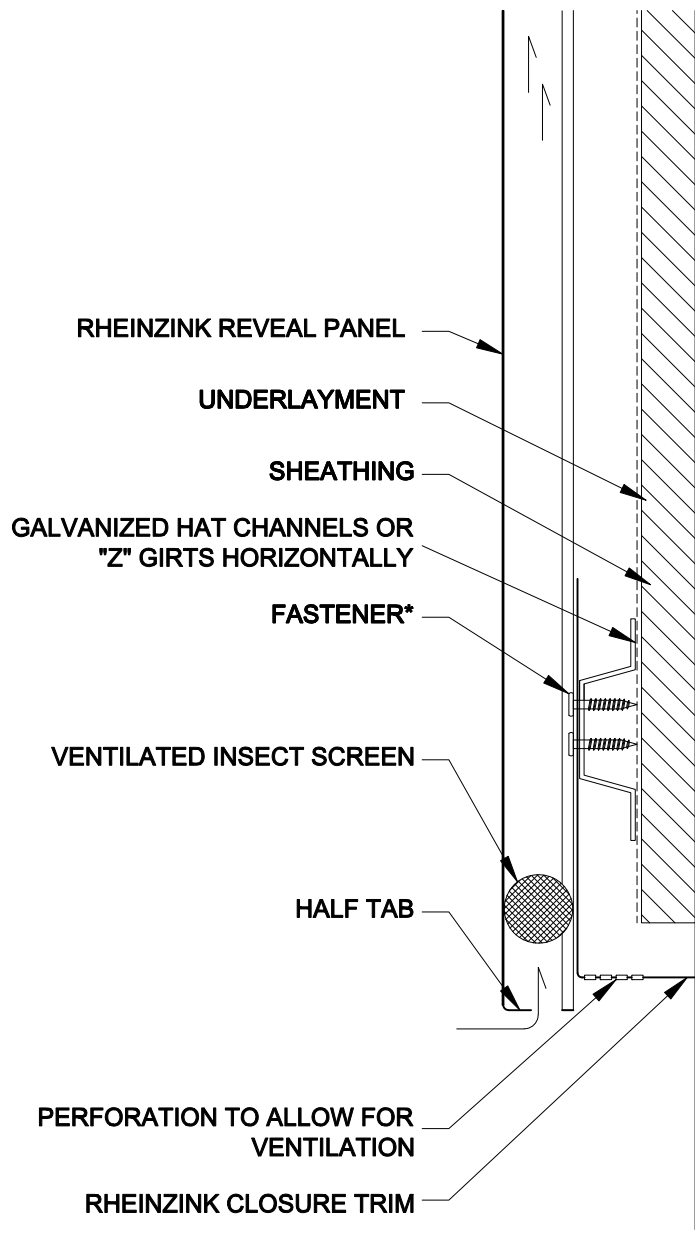

NOTES:

* RHEINZINK RECOMMENDS STAINLESS STEEL FASTENERS AND CLIPS.



Website: www.rheinzink.us E-mail: info@rheinzink.com

INFORMATION AND DETAILS HEREIN ARE ONLY A BASELINE FOR SYSTEM DESIGN AND INSTALLATION. MODIFICATION TO MEET PROJECT REQUIREMENTS IS THE RESPONSIBILITY OF THE DESIGNER AND ARCHITECT. RHEINZINK AMERICA STAFF ARE AVAILABLE TO ASSIST THE DESIGNER AND ARCHITECT IN THIS PROCESS. RHEINZINK AMERICA MAKES NO REPRESENTATIONS AND WARRANTIES OTHER THAN THOSE EXPRESSED HEREIN.

PROJECT:	REVEAL PANEL DETAILS - V	DATE:	11-2011
DRAWING TITLE:	BASE TERM. DETAIL - OPTION 2	SCALE:	N.T.S.
COPYRIGHT RESERVED. THIS DRAWING REMAINS THE PROPERTY OF RHEINZINK.		SHEET:	RP-V-6b

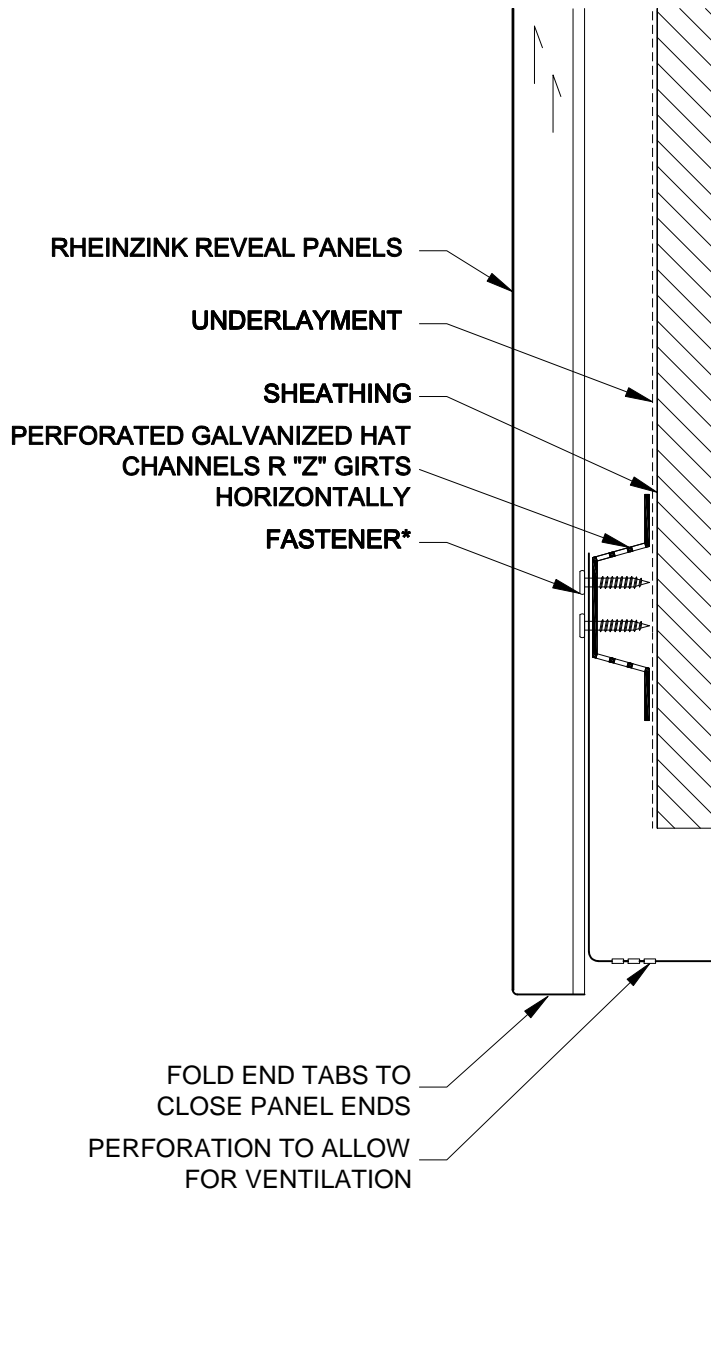

NOTES:

* RHEINZINK RECOMMENDS STAINLESS STEEL FASTENERS AND CLIPS.



Website: www.rheinzink.us E-mail: info@rheinzink.com

INFORMATION AND DETAILS HEREIN ARE ONLY A BASELINE FOR SYSTEM DESIGN AND INSTALLATION. MODIFICATION TO MEET PROJECT REQUIREMENTS IS THE RESPONSIBILITY OF THE DESIGNER AND ARCHITECT. RHEINZINK AMERICA STAFF ARE AVAILABLE TO ASSIST THE DESIGNER AND ARCHITECT IN THIS PROCESS. RHEINZINK AMERICA MAKES NO REPRESENTATIONS AND WARRANTIES OTHER THAN THOSE EXPRESSED HEREIN.

PROJECT:	REVEAL PANEL DETAILS - V	DATE:	10-2011
DRAWING TITLE:	BASE TERM. DETAIL - OPTION 3	SCALE:	N.T.S.
COPYRIGHT RESERVED. THIS DRAWING REMAINS THE PROPERTY OF RHEINZINK.		SHEET:	RP-V-6c

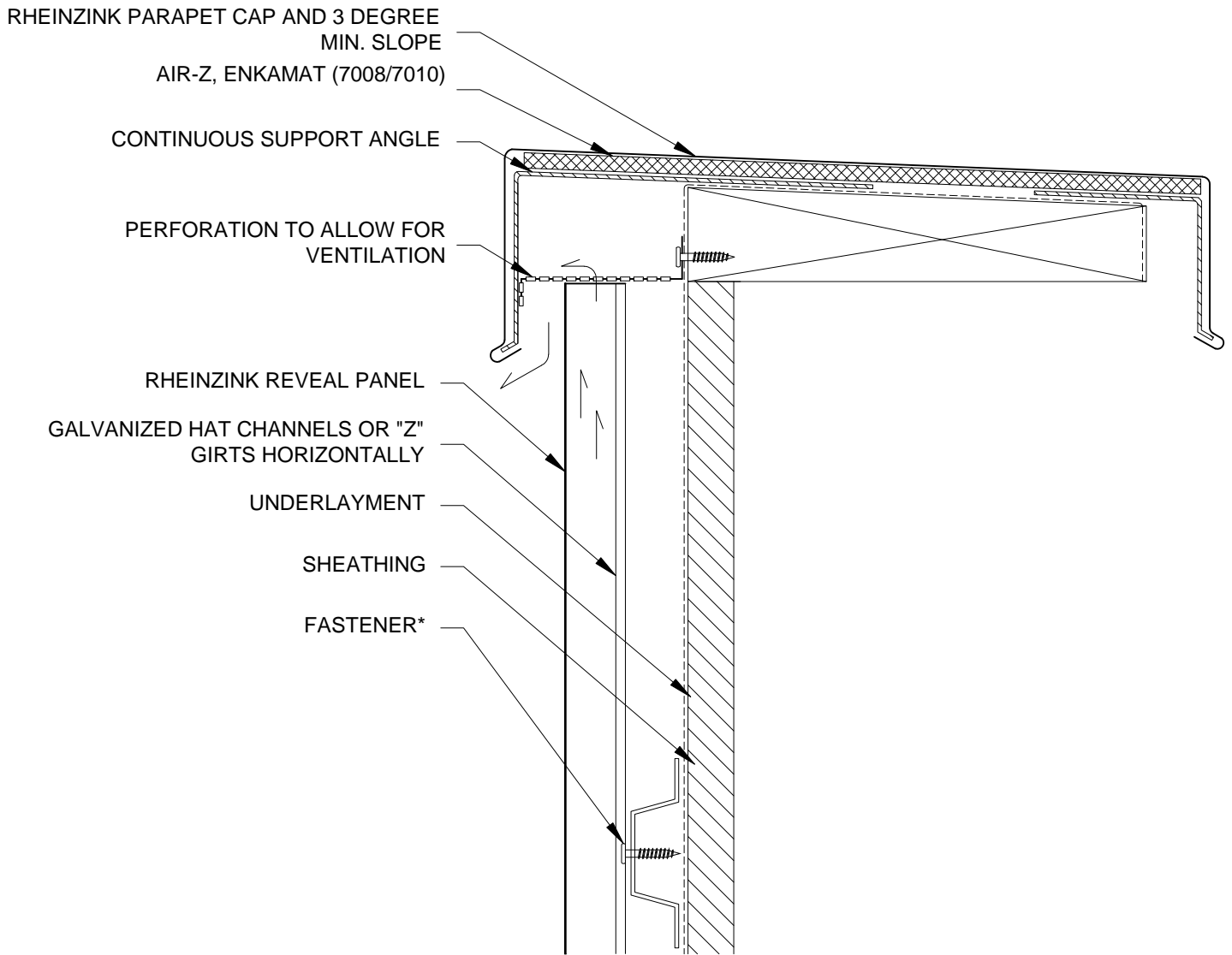

NOTES:

- * RHEINZINK RECOMMENDS STAINLESS STEEL FASTENERS AND CLIPS.



Website: www.rheinzink.us E-mail: info@rheinzink.com

INFORMATION AND DETAILS HEREIN ARE ONLY A BASELINE FOR SYSTEM DESIGN AND INSTALLATION. MODIFICATION TO MEET PROJECT REQUIREMENTS IS THE RESPONSIBILITY OF THE DESIGNER AND ARCHITECT. RHEINZINK AMERICA STAFF ARE AVAILABLE TO ASSIST THE DESIGNER AND ARCHITECT IN THIS PROCESS. RHEINZINK AMERICA MAKES NO REPRESENTATIONS AND WARRANTIES OTHER THAN THOSE EXPRESSED HEREIN.

PROJECT:	REVEAL PANEL DETAILS - V	DATE:	11-2011
DRAWING TITLE:	PARAPET DETAIL - OPTION 1	SCALE:	N.T.S.
COPYRIGHT RESERVED. THIS DRAWING REMAINS THE PROPERTY OF RHEINZINK.		SHEET:	RP-V-7a

RHEINZINK PARAPET CAP AND 3 DEGREE
MIN. SLOPE

AIR-Z, ENKAMAT (7008/7010)

CONTINUOUS SUPPORT ANGLE

PERFORATION TO ALLOW
FOR VENTILATION

RHEINZINK REVEAL PANEL

GALVANIZED HAT CHANNELS OR "Z"
GIRTS HORIZONTALLY

UNDERLAYMENT

SHEATHING

FASTENER*

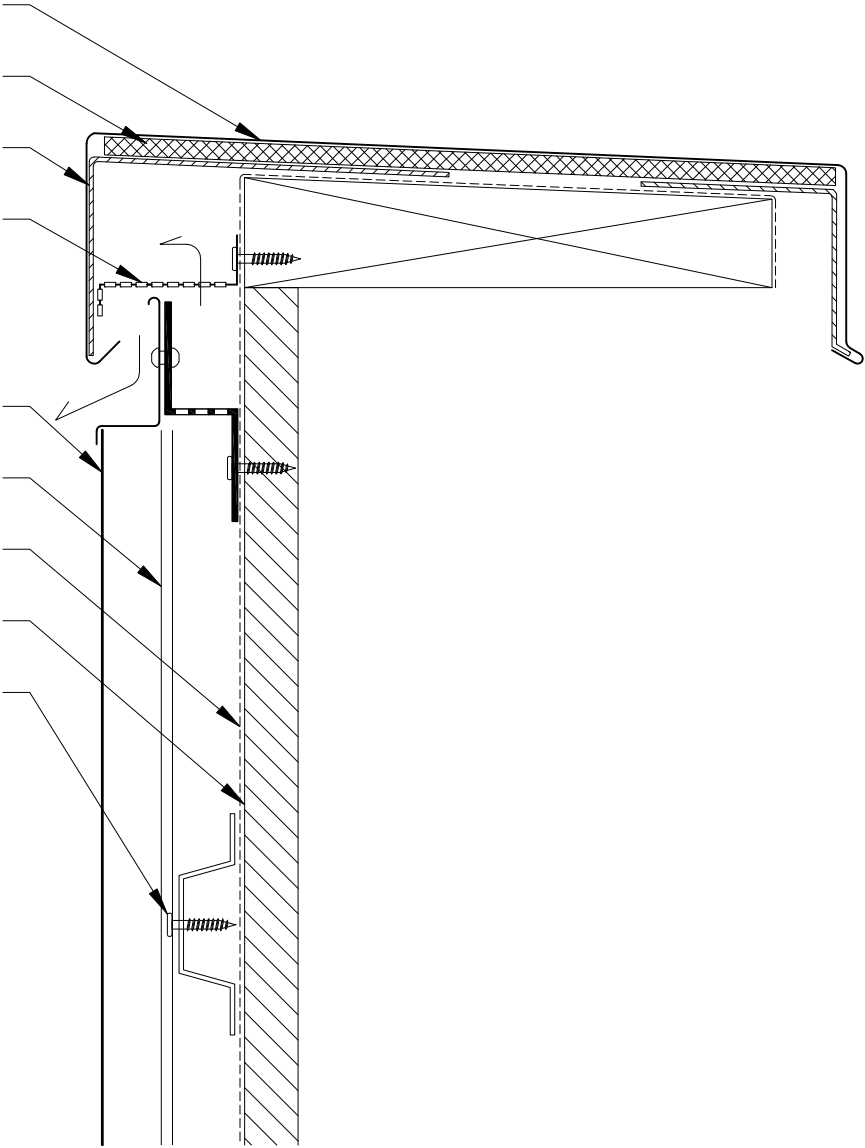

NOTES:

* RHEINZINK RECOMMENDS STAINLESS STEEL FASTENERS AND CLIPS.



Website: www.rheinzink.us E-mail: info@rheinzink.com

INFORMATION AND DETAILS HEREIN ARE ONLY A BASELINE FOR SYSTEM DESIGN AND INSTALLATION. MODIFICATION TO MEET PROJECT REQUIREMENTS IS THE RESPONSIBILITY OF THE DESIGNER AND ARCHITECT. RHEINZINK AMERICA STAFF ARE AVAILABLE TO ASSIST THE DESIGNER AND ARCHITECT IN THIS PROCESS. RHEINZINK AMERICA MAKES NO REPRESENTATIONS AND WARRANTIES OTHER THAN THOSE EXPRESSED HEREIN.

PROJECT:	REVEAL PANEL DETAILS - V	DATE:	11-2011
DRAWING TITLE:	PARAPET DETAIL - OPTION 2	SCALE:	N.T.S.
COPYRIGHT RESERVED. THIS DRAWING REMAINS THE PROPERTY OF RHEINZINK.		SHEET:	RP-V-7b

RHEINZINK PARAPET CAP AND 3 DEGREE
MIN. SLOPE
AIR-Z, ENKAMAT (7008/7010)

CONTINUOUS SUPPORT ANGLE
PERFORATION TO ALLOW
FOR VENTILATION

RHEINZINK REVEAL PANEL
GALVANIZED HAT CHANNELS OR "Z"
GIRTS HORIZONTALLY
UNDERLAYMENT
SHEATHING
FASTENER*

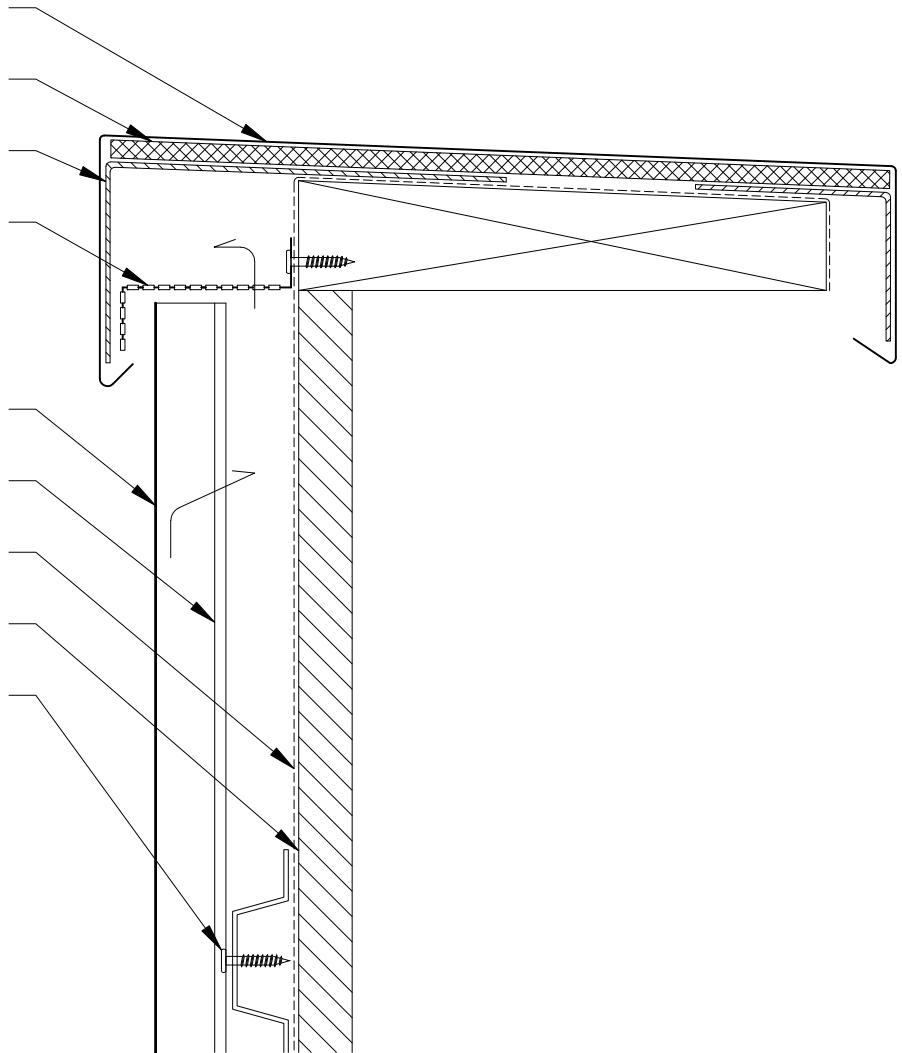

NOTES:

* RHEINZINK RECOMMENDS STAINLESS STEEL FASTENERS AND CLIPS.



Website: www.rheinzink.us E-mail: info@rheinzink.com

INFORMATION AND DETAILS HEREIN ARE ONLY A BASELINE FOR SYSTEM DESIGN AND INSTALLATION. MODIFICATION TO MEET PROJECT REQUIREMENTS IS THE RESPONSIBILITY OF THE DESIGNER AND ARCHITECT. RHEINZINK AMERICA STAFF ARE AVAILABLE TO ASSIST THE DESIGNER AND ARCHITECT IN THIS PROCESS. RHEINZINK AMERICA MAKES NO REPRESENTATIONS AND WARRANTIES OTHER THAN THOSE EXPRESSED HEREIN.

PROJECT:	REVEAL PANEL DETAILS - V	DATE:	10-2011
DRAWING TITLE:	PARAPET DETAIL - OPTION 3	SCALE:	N.T.S.
COPYRIGHT RESERVED. THIS DRAWING REMAINS THE PROPERTY OF RHEINZINK.		SHEET:	RP-V-7c

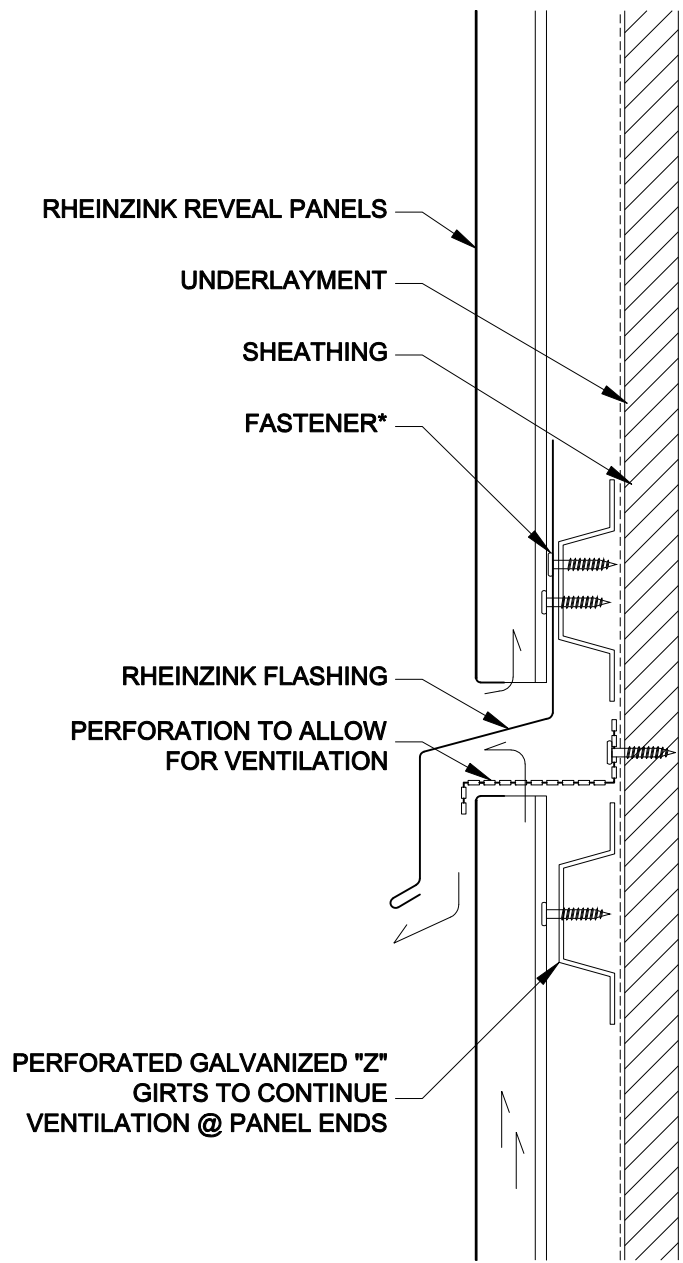

NOTES:

* RHEINZINK RECOMMENDS STAINLESS STEEL FASTENERS AND CLIPS.



Website: www.rheinzink.us E-mail: info@rheinzink.com

INFORMATION AND DETAILS HEREIN ARE ONLY A BASELINE FOR SYSTEM DESIGN AND INSTALLATION. MODIFICATION TO MEET PROJECT REQUIREMENTS IS THE RESPONSIBILITY OF THE DESIGNER AND ARCHITECT. RHEINZINK AMERICA STAFF ARE AVAILABLE TO ASSIST THE DESIGNER AND ARCHITECT IN THIS PROCESS. RHEINZINK AMERICA MAKES NO REPRESENTATIONS AND WARRANTIES OTHER THAN THOSE EXPRESSED HEREIN.

PROJECT:	REVEAL PANEL DETAILS - V	DATE:	11-2011
DRAWING TITLE:	CROSS SEAM DETAIL - OPTION 1	SCALE:	N.T.S.
COPYRIGHT RESERVED. THIS DRAWING REMAINS THE PROPERTY OF RHEINZINK.		SHEET:	RP-V-8a

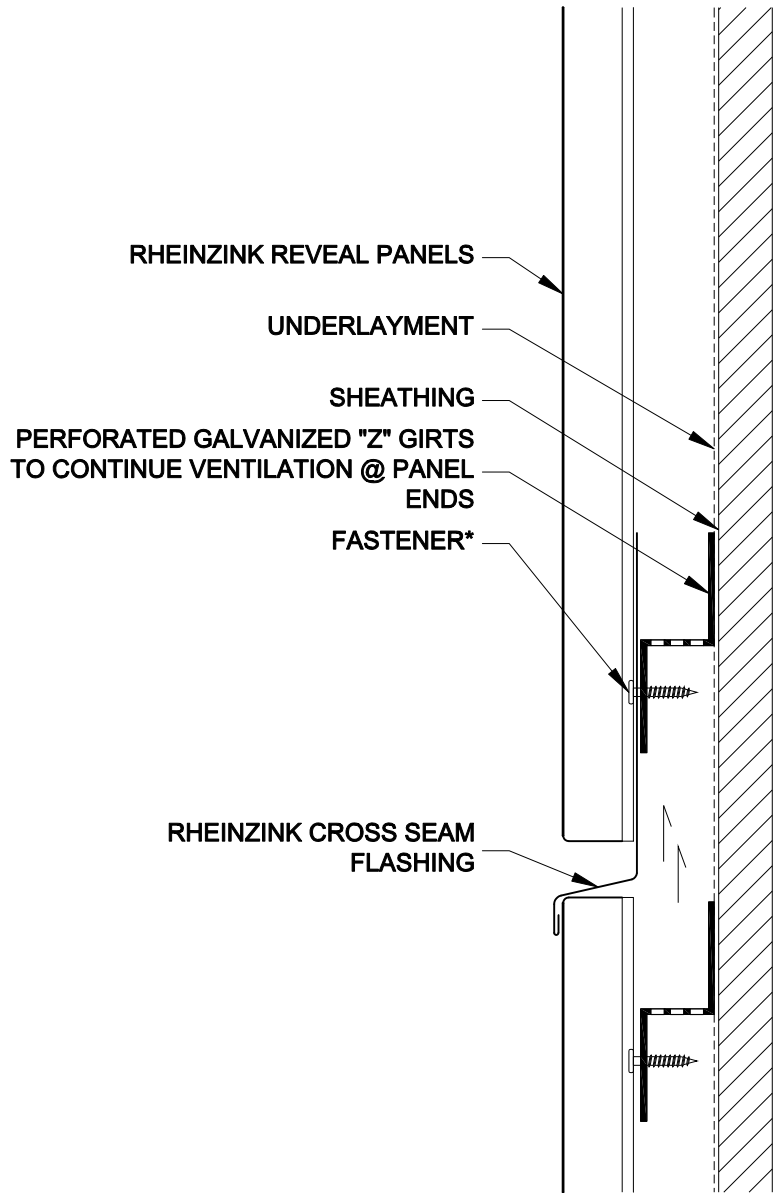

NOTES:

- * RHEINZINK RECOMMENDS STAINLESS STEEL FASTENERS AND CLIPS.



Website: www.rheinzink.us E-mail: info@rheinzink.com

INFORMATION AND DETAILS HEREIN ARE ONLY A BASELINE FOR SYSTEM DESIGN AND INSTALLATION. MODIFICATION TO MEET PROJECT REQUIREMENTS IS THE RESPONSIBILITY OF THE DESIGNER AND ARCHITECT. RHEINZINK AMERICA STAFF ARE AVAILABLE TO ASSIST THE DESIGNER AND ARCHITECT IN THIS PROCESS. RHEINZINK AMERICA MAKES NO REPRESENTATIONS AND WARRANTIES OTHER THAN THOSE EXPRESSED HEREIN.

PROJECT:	REVEAL PANEL DETAILS - V	DATE:	08-2011
DRAWING TITLE:	CROSS SEAM DETAIL - OPTION 2	SCALE:	N.T.S.
COPYRIGHT RESERVED. THIS DRAWING REMAINS THE PROPERTY OF RHEINZINK.		SHEET:	RP-V-8b

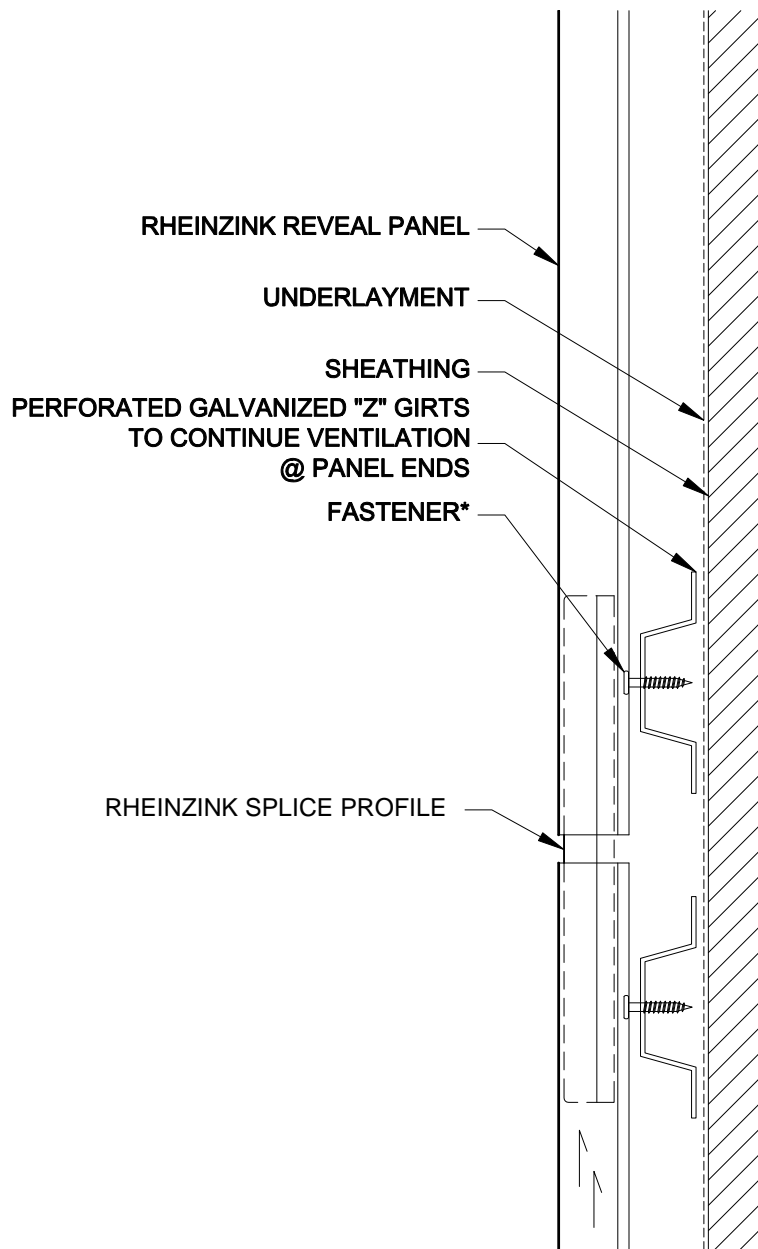

NOTES:

- * RHEINZINK RECOMMENDS STAINLESS STEEL FASTENERS AND CLIPS.



Website: www.rheinzink.us E-mail: info@rheinzink.com

INFORMATION AND DETAILS HEREIN ARE ONLY A BASELINE FOR SYSTEM DESIGN AND INSTALLATION. MODIFICATION TO MEET PROJECT REQUIREMENTS IS THE RESPONSIBILITY OF THE DESIGNER AND ARCHITECT. RHEINZINK AMERICA STAFF ARE AVAILABLE TO ASSIST THE DESIGNER AND ARCHITECT IN THIS PROCESS. RHEINZINK AMERICA MAKES NO REPRESENTATIONS AND WARRANTIES OTHER THAN THOSE EXPRESSED HEREIN.

PROJECT:	REVEAL PANEL DETAILS - V	DATE:	02-2012
DRAWING TITLE:	CROSS SEAM DETAIL - OPTION 3	SCALE:	N.T.S.
COPYRIGHT RESERVED. THIS DRAWING REMAINS THE PROPERTY OF RHEINZINK.		SHEET:	RP-V-8c

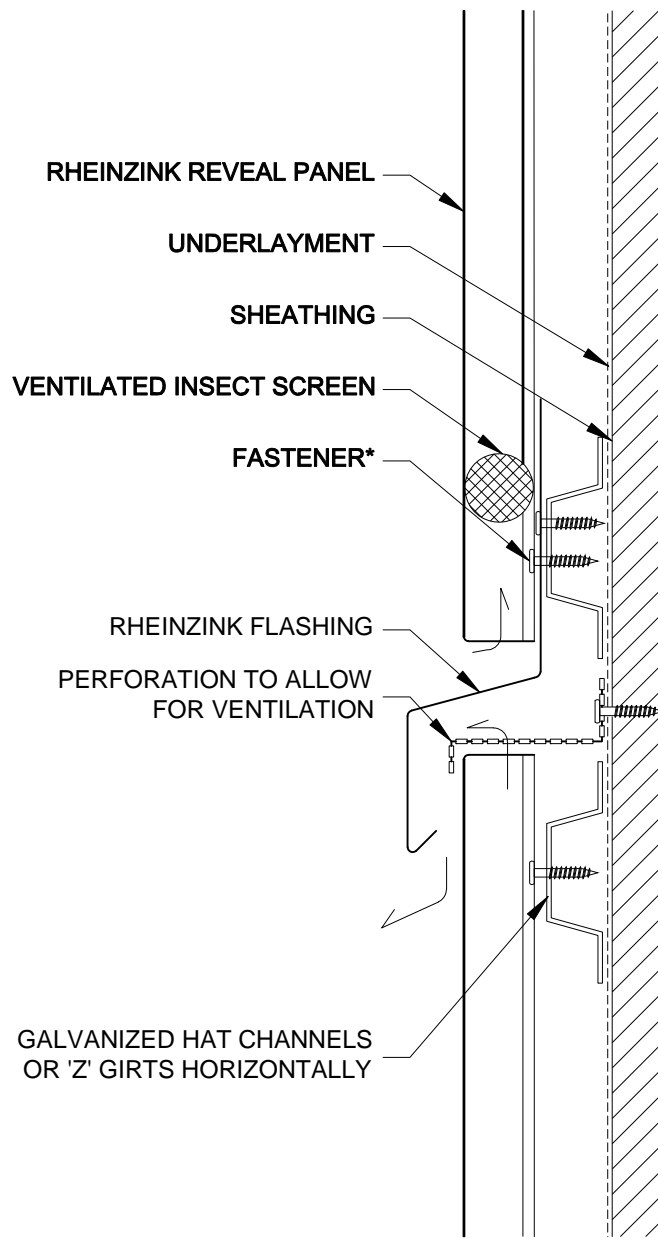

NOTES:

* RHEINZINK RECOMMENDS STAINLESS STEEL FASTENERS AND CLIPS.



Website: www.rheinzink.us E-mail: info@rheinzink.com

INFORMATION AND DETAILS HEREIN ARE ONLY A BASELINE FOR SYSTEM DESIGN AND INSTALLATION. MODIFICATION TO MEET PROJECT REQUIREMENTS IS THE RESPONSIBILITY OF THE DESIGNER AND ARCHITECT. RHEINZINK AMERICA STAFF ARE AVAILABLE TO ASSIST THE DESIGNER AND ARCHITECT IN THIS PROCESS. RHEINZINK AMERICA MAKES NO REPRESENTATIONS AND WARRANTIES OTHER THAN THOSE EXPRESSED HEREIN.

PROJECT:	REVEAL PANEL DETAILS - V	DATE:	11-2011
DRAWING TITLE:	CROSS SEAM DETAIL - OPTION 4	SCALE:	N.T.S.
COPYRIGHT RESERVED. THIS DRAWING REMAINS THE PROPERTY OF RHEINZINK.		SHEET:	RP-V-8d

REVEAL WIDTHS CAN VARY FROM
0" TO 1". THIS IS ACCOMPLISHED
BY THE APPROPRIATE SCALING
OF THE "TONGUE"

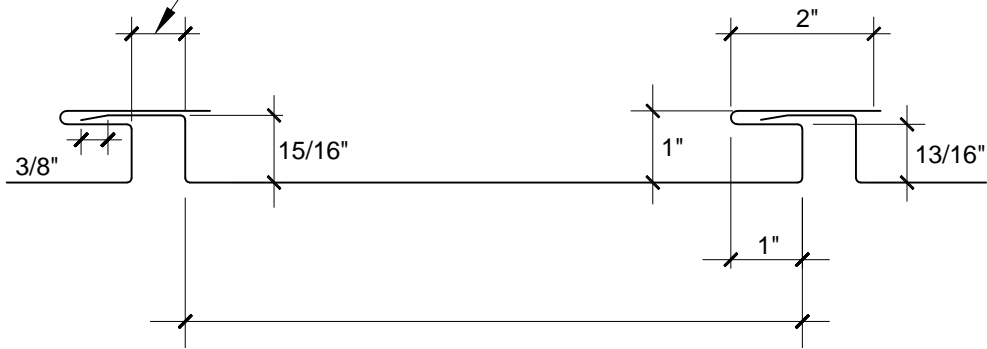

PANELS CAN BE MADE IN BAY
WIDTHS BETWEEN **7" AND 13"**
MATERIAL THICKNESSES: 0.8mm, 1.0mm and 1.2mm

NOTES:

- * RHEINZINK RECOMMENDS STAINLESS STEEL FASTENERS AND CLIPS.



Website: www.rheinzink.us E-mail: info@rheinzink.com

INFORMATION AND DETAILS HEREIN ARE ONLY A BASELINE FOR SYSTEM DESIGN AND INSTALLATION. MODIFICATION TO MEET PROJECT REQUIREMENTS IS THE RESPONSIBILITY OF THE DESIGNER AND ARCHITECT. RHEINZINK AMERICA STAFF ARE AVAILABLE TO ASSIST THE DESIGNER AND ARCHITECT IN THIS PROCESS. RHEINZINK AMERICA MAKES NO REPRESENTATIONS AND WARRANTIES OTHER THAN THOSE EXPRESSED HEREIN.

PROJECT:	PANEL PROFILE	DATE:	08-2011
DRAWING TITLE:	HEAD DETAIL - OPTION 1	SCALE:	N.T.S.
COPYRIGHT RESERVED. THIS DRAWING REMAINS THE PROPERTY OF RHEINZINK.		SHEET:	RP-V-9